

# INSTALLATION INSTRUCTIONS

READ IMPORTANT SAFETY TIPS BEFORE PROCEEDING WITH INSTALLATION

## SAFETY TIPS

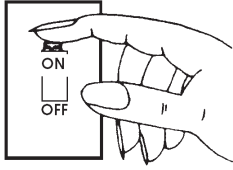

Turn fixture off! (Place wall switch in off position, if fixture has built-in switch or chain pull, switch or pull chain so fixture is off.)

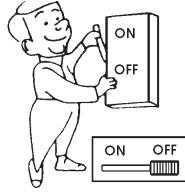

Next - go to the main fuse box. If your fuse box has an ON/OFF switch, simply place main power switch in OFF position.

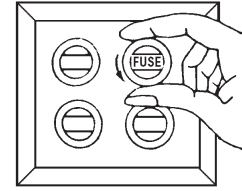

Screw-in type fuses - unscrew the fuse or fuses that control the power to the fixture or room you are working in.

# 1

### OUTLET BOX MOUNT

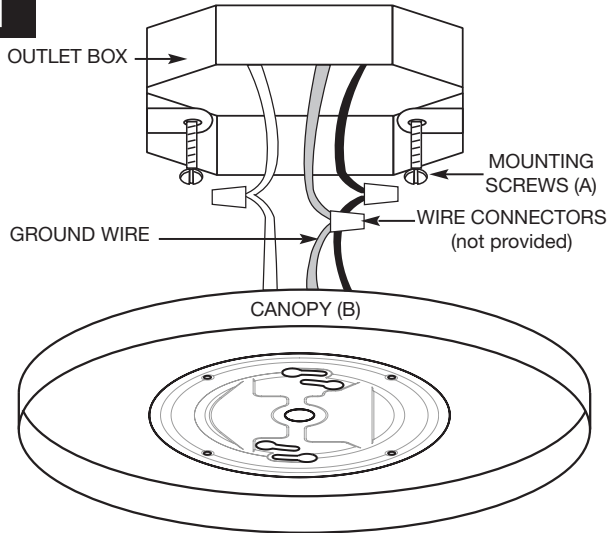

Thread 1" long mounting screws (A) into outlet box. Be sure to leave enough of the screw extended to allow the attachment of the canopy (B).

**A.** Take black fixture wire(s) and place evenly against the black wire from the outlet box. **Do Not** twist wires together before using wire connectors. Fit a wire connector over the wires and thread the connector clockwise until you feel a firm resistance.

**B.** Take white fixture wire(s) and place evenly against the white wire from the outlet box. **Do Not** twist wires together before using wire connectors. Fit a wire connector over the wires and thread the connector clockwise until you feel a firm resistance.

**C.** Take green fixture wire and place evenly against the ground wire from the outlet box. **Do Not** twist wires together before using wire connectors. Fit a wire connector over the wires and thread the connector clockwise until you feel a firm resistance.

# 2

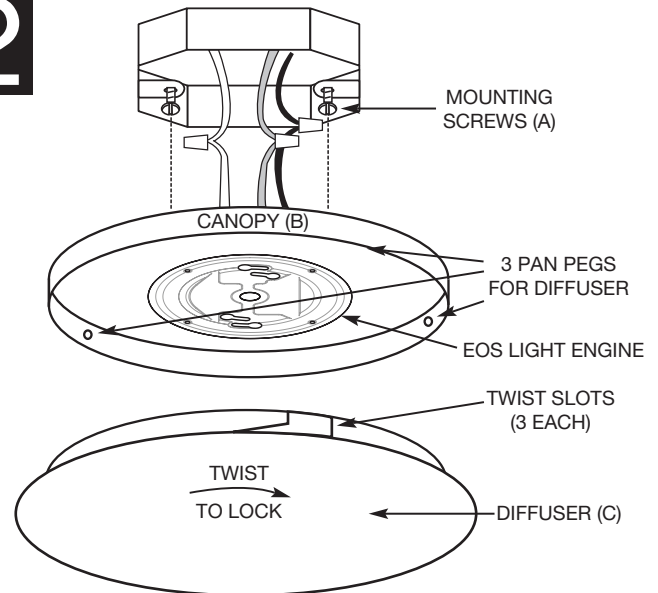

**Make sure no bare wires can be seen outside wire connectors.**

After the wires are connected, carefully tuck them into the outlet box. Position canopy (B) to outlet box and secure with mounting screws (A). Select appropriate keyhole slots.

Attach diffuser (C) by aligning slots with pegs on canopy (B) and pushing the diffuser upward and rotating clockwise.

**NOTE:** IN ORDER FOR THE LIGHTING FIXTURE TO OPERATE PROPERLY, THE BUILDING'S ELECTRICAL SYSTEM MUST BE GROUNDED. IF YOU ARE UNCLEAR AS TO HOW TO PROCEED, CONSULT A QUALIFIED ELECTRICIAN.



**CLEAN ONLY WITH MILD SOAP AND WATER. AVOID SPRAYING WITH CLEANSERS, INSECTICIDES, AND PESTICIDES THAT ARE PETROLEUM BASED HYDROCARBON PRODUCTS. THESE WILL DEGRADE LUMINAIRE.**

**CAUTION: Do not turn on without diffuser installed. Do not touch LEDs or circuit board. LED optics could be damaged. No lamp replacement required! Integral LED light engine supplied. Do not remove protective cover from LED light engine.**

### FIVE YEAR (60 MONTH) LIMITED WARRANTY

Inter-Global warrants this lighting fixture to be free from defects in material and workmanship for a period of five (5) years from the date of purchase and agrees, at its option, to repair or replace any defective product without charge. **IMPORTANT: THIS WARRANTY DOES NOT COVER ANY DAMAGE RESULTING FROM ACCIDENT, MISUSE OR ABUSE, ABNORMAL USAGE, FAULTY INSTALLATION, NON-RESIDENTIAL USE, NEGLIGENCE, DAMAGE IN TRANSIT, OR REPAIR OR ALTERATIONS TO THE PRODUCT, IMPROPER MAINTENANCE, OR ANY CAUSE, OTHER THAN OUR DEFECTIVE MATERIAL OR WORKMANSHIP.**

For warranty service, call Inter-Global at 800-325-7364 to request RGA.

**NOTE:** Inter-Global shall not be liable for any special, incidental, or consequential damages arising out of or in connection with the use, manufacture, design, sale, or performance of its products.

No other warranties, express or implied, written or oral are authorized by Inter-Global. ALL IMPLIED WARRANTIES, INCLUDING THE WARRANTIES OF MERCHANTABILITY AND FITNESS FOR A PARTICULAR PURPOSE SHALL BE LIMITED IN DURATION FOR A PERIOD OF 60 MONTHS FROM THE ORIGINAL DATE OF PURCHASE. Seller shall in no event be liable for any breach of warranty in an amount that exceeds the price of the specific product.

This warranty gives you specific legal rights. You may also have other rights which vary from state to state. Some states do not allow the exclusion or limitation of incidental or consequential damages or the limitation on the duration of how long an implied warranty lasts, so the above exclusions and limitations may not apply to you.

Inter-Global takes pride in this production and we hope that it brings you many years of enjoyment. If you have comments, please call 800-325-7364.