

## Features

- White Composite Decorative Ring
- White Enamel Steel Pan
- Opal White or Clear Prism Acrylic Lens
- 120/277V 50/60Hz
- Buy American Compliant
- 5 Year Warranty
- Damp Location Listed
- Dimmable
- LED Models 50,000hr L70



## Applications

- Damp Location Listed
- Ceiling Mount

## Wattage/Lumens

### Wattage/120/277V Integrated Systems

- 10W Integrated LED
  - (3000K-1012lm)
  - (4000K-1065lm)
  - (5000K - 1086lm)
- 15W Integrated LED
  - (3000K-1639lm)
  - (4000K-1725lm)
  - (5000K - 1760lm)

## Options

## Dimensions

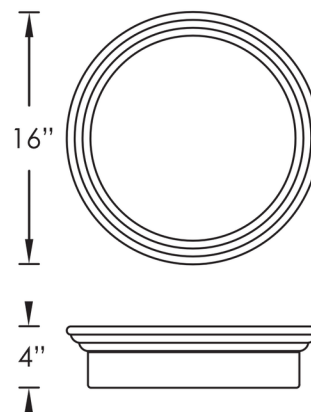

## Warranty

- 5 Year

## ORDERING GUIDE

Example: 11711-15LMV-30K

Family	Lens Color	Base Color	Wattage	CCT	Options
117	1 - White 9 - Clear Prism	1 - White	10LMV - 10W 15LMV - 15W	30K - 3000K 40K - 4000K 50K - 5000K	
		<b>Special Finishes**</b> 3 - Brush Rust 5 - Black 7 - Ultra Chrome			