

Features

- Black or White Cross Cage Frame
- (LED Models) Corrosion Resistant Aluminum Back Pan
- (E26 Model) Composite Base
- Impact Resistant Polycarbonate Diffuser
- Residential Energy Star (Certain Wattages)***
- Made in America Compliant
- Dimmable**

** All wattages are dimmable except **11LMV** model

*** Energy Star Listed for **13LED-120** & **11LMV** models



Applications

- Wall Mount Only
- Outside Use Only

Wattage/Lumens

E26 Medium Base Systems

- Medium E26 Base (60W Max) (Bulb Not Included)

120V Integrated LED Systems

- 13W Integrated LED
 - (3000K-1140lm)
 - (4000K-1280lm)

120/277V Integrated LED Systems

- 11W Integrated LED
 - (4000K-912lm)

Warranty

- 5-Year LED
- 3-Year Medium Base

Options

- Photocell (120V)

Dimensions

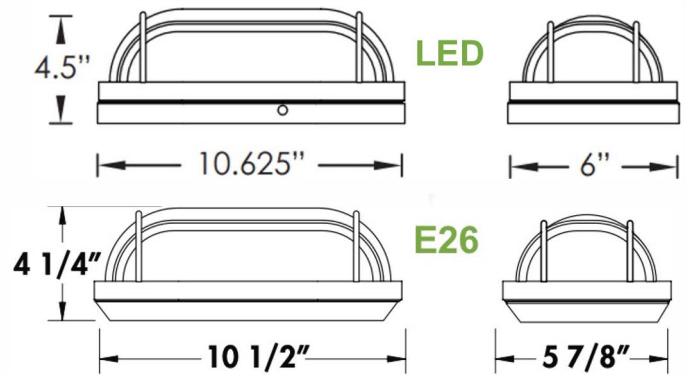

ORDERING GUIDE

Example: 33565-13LED-120-30K

Family	Lens Color	Base Color	Wattage	CCT	Options
335	6 - Frosted	1 - White 5 - Black	E26 - Medium Base [^]	_____	_____
			13LED-120 - 13 Watt	30K - 3000K 40K - 4000K	PE - Photocell
			11LMV - 11.3 Watt	40K - 4000K	_____