

COMPOSITE **Hudson Series 405**

DESCRIPTION

Enhance your outdoor space with the modern style of Incon's Hudson 405 Series. It is constructed from a UV-resistant composite material with a non-rusting and anti-chip finish for long lasting use. Available in black, bronze, or white. This light features a clear or anti-glare LED frosted acrylic lens and weather-resistant construction that shield from environmental damage.

FEATURES

- Non-corrosive, Anti-chip Composite Housing is UV Resistant
- Black, Bronze or White Anti-rust Finish For Long Life
- Anti-Glare LED™ Frost Acrylic Lens
- Weather-resistant Construction Protects Against Damage
- Available in Integrated LED or E26 Medium Socket
- 120V 50/60Hz
- Buy American Act Compliant
- Warranty (5-Year LED) (3-Year Medium Base)
- LED Models 50,000hr L70

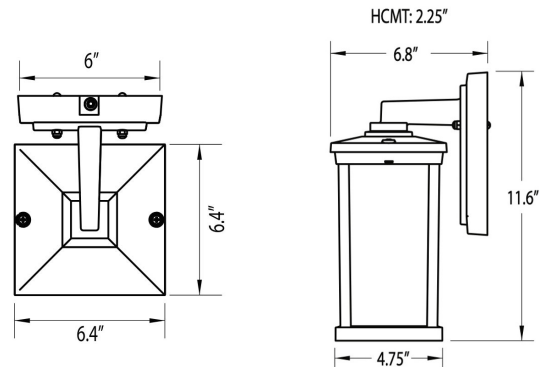

WATTAGE/LUMENS

E26 Medium Base LED A19 Ready

- E26 Medium Base
 - LED A19 Ready (Bulb Not Included)
 - Incandescent (60W Max) (Bulb Not Included)

120V Integrated LED Systems

- 13W Integrated LED (Dimmable)
 - (3000K - 1140lm)
 - (4000K - 1280lm)

ORDERING GUIDE (Sample: 40565-13LED-120-30K)

Family	Lens Color	BASE COLOR	Wattage	CCT	Options
405	6 - Frost	5 - Black	E26 - Medium Base	-	PE - Photocell (120V) S - Motion/Photocell Sensor
	9 - Clear	Special Order**	13LED-120 - 13 Watt	30K - 3000K	
		1 - White		40K - 4000K	
		3B - Bronze			

Specifications subject to change without notice

FEATURES



sales@inconlighting.com Ph. 407-323-5630
Rev 06/24 www.inconlighting.com/405

OPTIONS



PROJECT: _____

SCHEDULE: _____ DATE: _____

PREPARED BY: _____

NOTES: _____