

COMPOSITE **Eola Series 807**

**DESCRIPTION**

Illuminate your walkways and yard with the Eola 807 series outdoor coach post top light. It is also available with an optional pier mount. The fixture is constructed from a non-corrosive, UV-resistant plastic material with a non-rusting and anti-chipping white or black finish for long-lasting good looks. Best for poles 12 ft or less. Great for residential or multi-family. Available in Integrated LED or E26 Medium Base

**FEATURES**

- Non-corrosive - Anti-chip Composite Housing
- UV Resistant for Outdoor installation
- Black, Bronze, or White Finish
- Anti-Glare LED™ Frost Acrylic Shade
- Available in Integrated LED or E26 Medium Socket (LED A19 Ready)
- Fits on most 3" Diameter Post (Not Included)
- 120V 50/60Hz
- Buy American Act Compliant
- Triac Dimmable (13LED-120)
- Warranty (5-Year LED) (3-Year Medium Base)
- LED Models 50,000hr L70

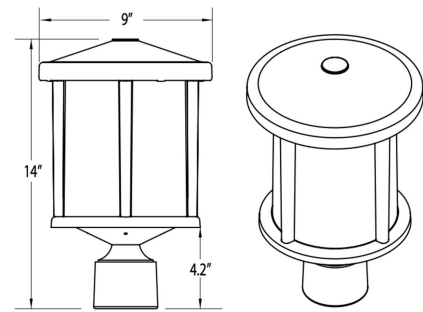

**WATTAGE/LUMENS**

**E26 Medium Base LED A19 Ready**

- E26 Medium Base
  - LED A19 Ready
  - Incandescent (60W Max) (Bulb Not Included)

**120V Integrated LED Systems**

- 13W Integrated LED (Dimmable)
  - (3000K - 1140lm)
  - (4000K - 1280lm)

**ORDERING GUIDE** (Sample: 80765-13LED-120-30K)

Family	Lens Color	BASE COLOR	Wattage	CCT	Options
807	6 - Frost	5 - Black	E26 - Medium Base	-	<b>PCAS</b> - Photocell Blk Adapter <b>PMB</b> - Black Pier Mount
	9 - Clear	Special Order**	13LED-120 - 13 Watt	30K - 3000K	
		1 - White		40K - 4000K	
		3B - Bronze			

Specifications subject to change without notice

**FEATURES**



**ADDITIONAL NOTES**

PROJECT: \_\_\_\_\_

SCHEDULE: \_\_\_\_\_ DATE: \_\_\_\_\_

PREPARED BY: \_\_\_\_\_

NOTES: \_\_\_\_\_